

5W Industrial Crystalline Solar Module

CSE industrial 12V crystalline solar modules are designed to provide dependable & renewable power under all weather conditions.

Features:

- Completely weatherproof
- Rugged industrial construction making it ideal for all applications
- Pre-wired junction box & robust anodized aluminum frame with pre-drilled holes for quick installation
- Tempered glass lamination
- Designed for All off grid battery charging applications

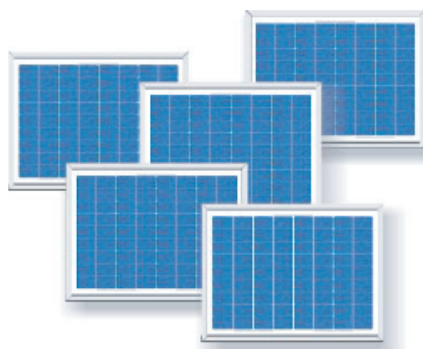

CSE-SA5C

Characteristics

Model	CSE-SA5C
Open circuit voltage (Voc)	21.4V
Optimum operating voltage (Vmp)	16.8 V
Short circuit current (Isc)	0.32A
Optimum operating current (Imp)	0.3A
Maximum power at STC (Pm)	5Wp

STC: Irradiance 1000W/m², Module temperature 25°C, AM=1.5

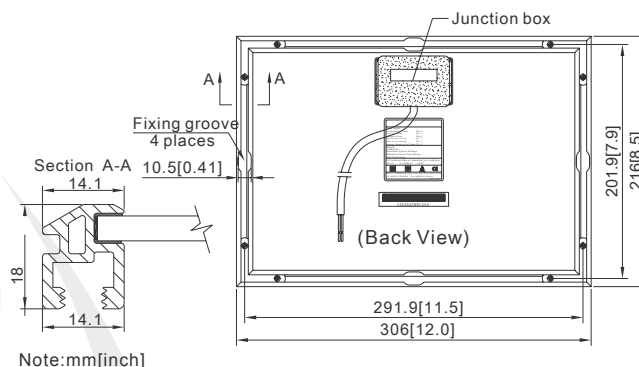

Specifications

Cell	Multicrystalline silicon solar cells 62.5mm×15.62mm
No. of cells and connections	36(4×9)
Dimension of module (mm)	216×306×18
Weight	0.8 kg
Certification	IEC-61215
Warranty	10 years limited warranty on power output 1 year limited warranty on materials and workmanship

Output

Type of output terminal	Junction box
Cable	(+) and (-) wire leads
Lengths	500mm

Temperature and Coefficients

NOCT	48°C ± 2°C	
Current temperature coefficient	%/K	0.06 ± 0.01
Voltage temperature coefficient	mV/K	-(155 ± 10)
Power temperature coefficient	%/K	-(0.5 ± 0.05)

NOCT: Nominal Operation Cell Temperature

Limits

Operating temperature	-40 to +85°C
Maximum system voltage	715 V DC